

Goodyear Tire and Rubber Co. Summer 2022 Plant Rotation

Austin Nacarato – Washkewicz College of Engineering – Mechanical Engineering



Choose **Ohio** First

INTRODUCTION

I am a Senior Mechanical Engineering student at Cleveland State University. I have completed two summer co-op rotations with Goodyear Tire and Rubber Company. The first occurred in the summer of 2021 where I was a member of Global Engineering at the Global Headquarters in Akron, Ohio. For my second rotation, I was posted in Goodyear's Topeka, Kansas Plant.

ABSTRACT

This poster serves as an overview of my co-op experience in the Goodyear Tire and Rubber Co. Topeka, Kansas Plant as a member of Plant Engineering. I will be outlining my projects, relation to course material, skills gained, and lessons learned. It will also show the value added to the company and give insight into the rubber industry. Lastly, it serves as a representation of co-op experiences as a whole and the process of transitioning from student to intern and intern to full time employee.

MAJOR PROJECTS

- Investigate use of decommissioned mixer line gearbox as a spare for 5 other lines
- New guarding design for mixer drop gate area complying with updated internal safety regulations
- Assist in overseeing replacement of gearbox, pinion, and bull gear on calendar roll

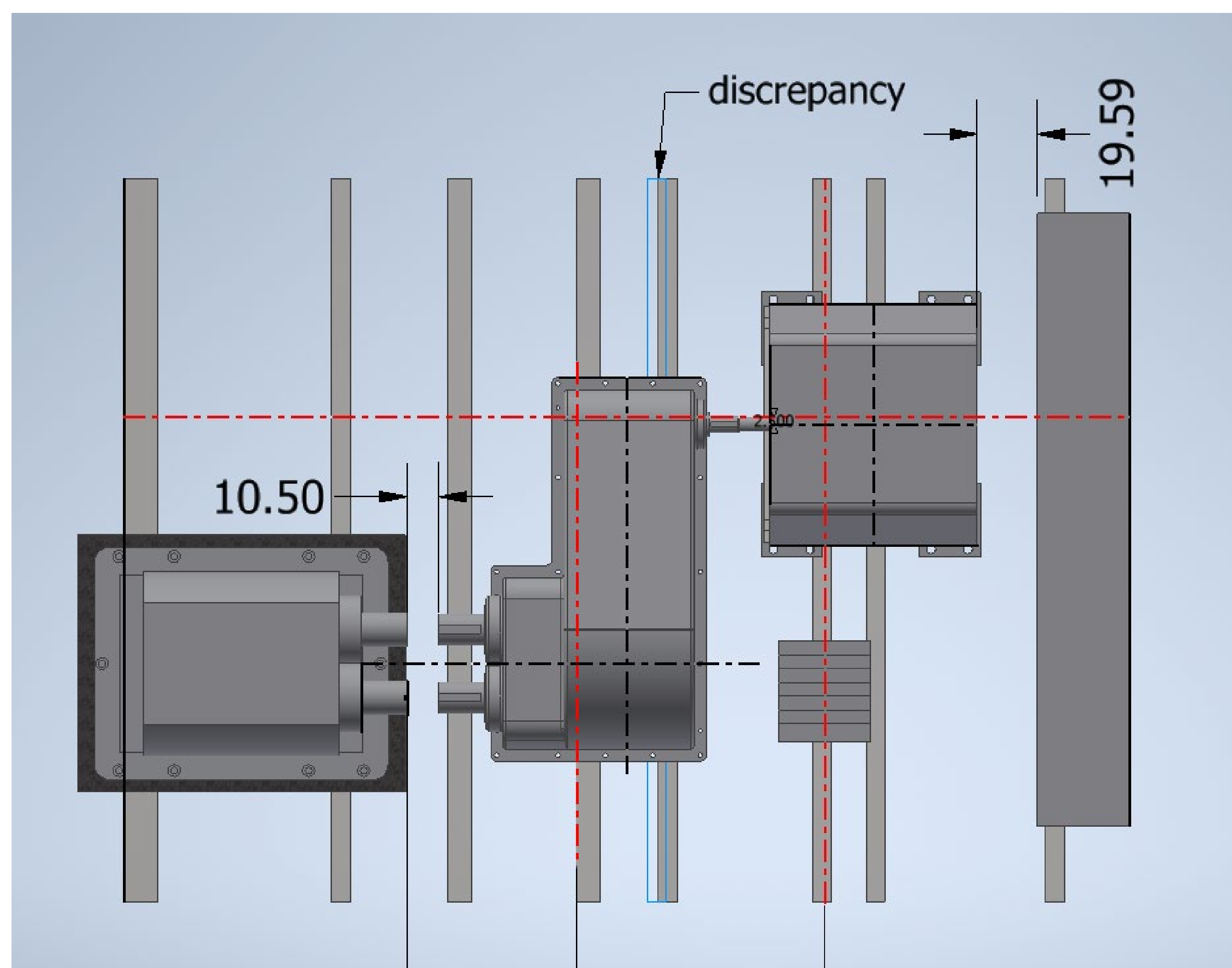

Layout for a specific mixer line optimized for anchor bolt locations

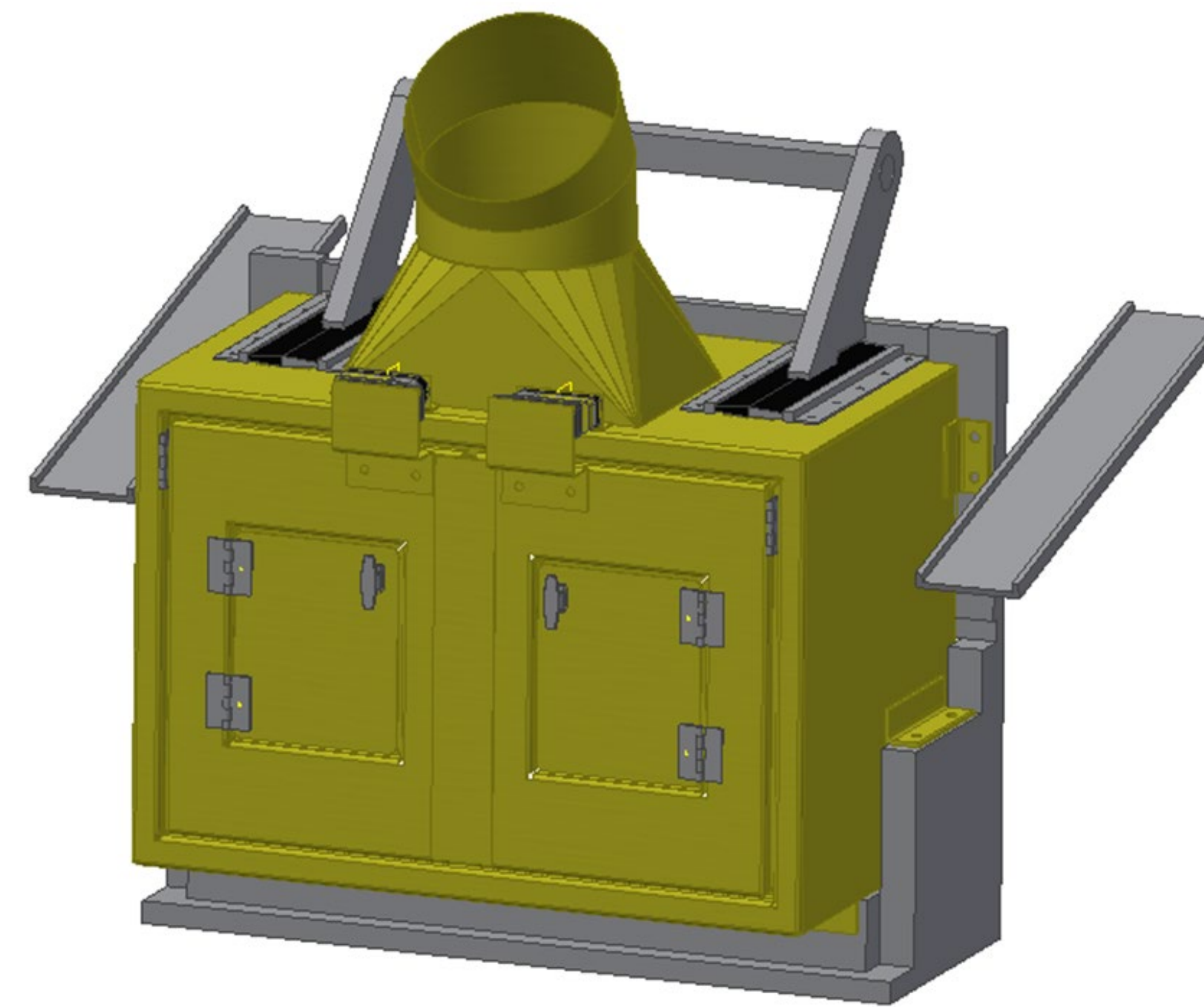

Completed drop gate guard featuring magnetic safety switches and fume hood for dust collection

CHALLENGES

- Gearbox
 - Civil layouts for each mixer line had to be found, scanned, and verified with location measurements
 - Some locations would require shifting the current motor and gearbox pads both horizontally and vertically with consideration of anchor bolt locations
- Drop gate guard
 - No engineering drawings were available for the mixer
 - Design needed to be easily removed with tools, but also seal to prevent dust from escaping

CONCLUSIONS

- Due to the incorrect gear ratio for all locations, it was determined that purchasing a new gearbox would be more cost-effective
- The drop gate guard design was sent out for quote and was being built by the in-plant sheet metal fabricator when my rotation was over
- Drop gate design dimensions will need to be adjusted for each mixer

VALUE ADDED TO THE COMPANY

- Safety improvement for mixer operators and maintenance crew
- Successful calendar mill project allows for another 100 years of operation
- Best course of action for spare mixer gearboxes and civil layouts for several locations
- Minor projects
 - Welded connection to bolted connection that reduces downtime from 8 hours to 3 hours
 - Research on layouts for bulk bag unloaders

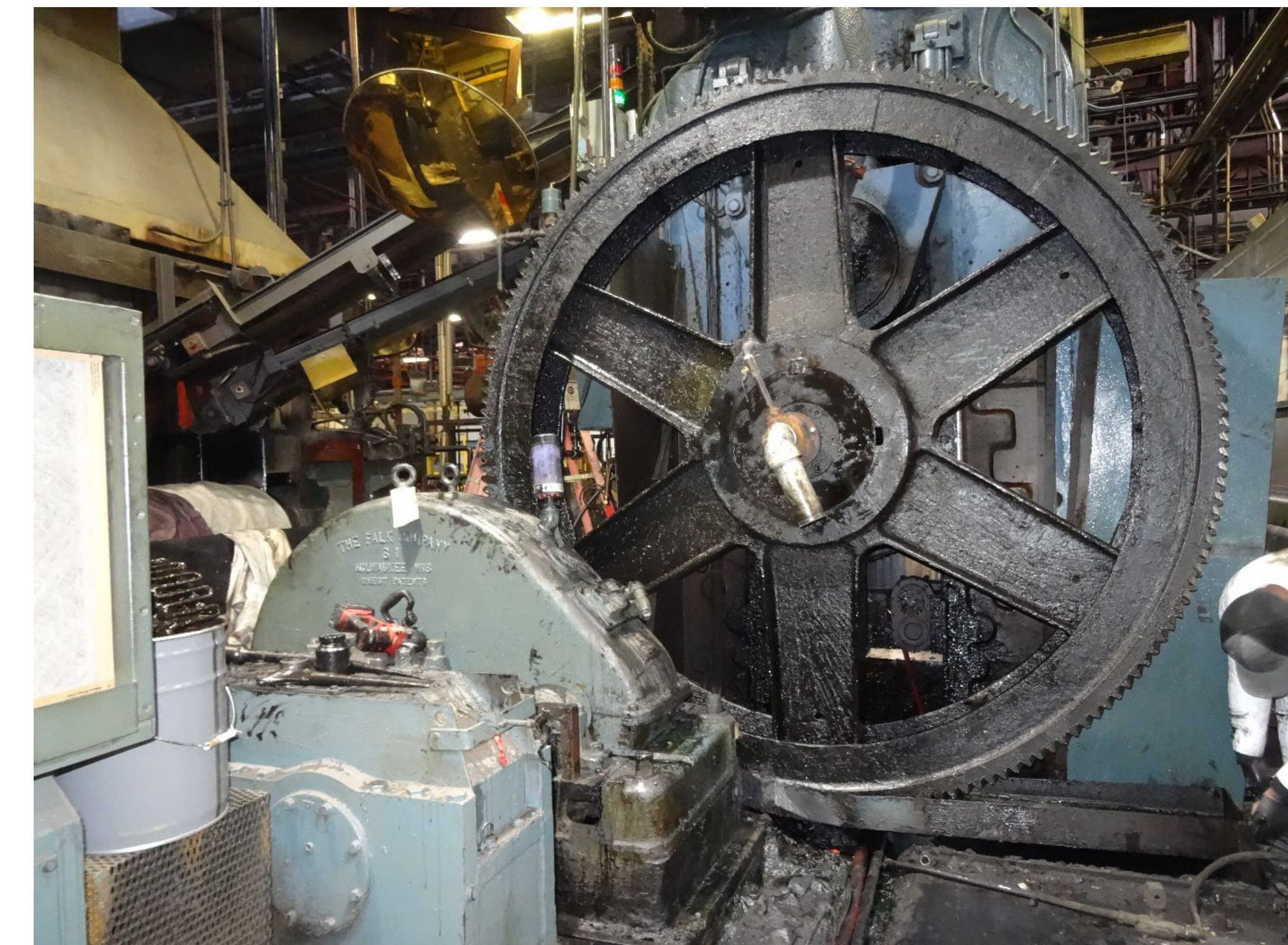

Calendar mill before work was performed

EXPERIENCE GAINED

- Project management
- Communication with suppliers and plant labor, including union representatives
- Tire and rubber manufacturing process
- Machine anchoring and civil layouts
- Machine guarding design with emphasis on design for harsh environments
- Gear ratios and gearbox design

Acknowledgments

- Goodyear Tire and Rubber Co.
- John Ullrich – Technical mentor